

SMART DIFFERENTIAL

ELPRT-100SDP

PRESSURE TRANSMITTER



ELPRT-100SDP



ELPRT-100SDP
With Remote Seal

FEATURES

- Capacitive Sensor with Diaphragm
- ATEX Certified
- Rigid Construction
- Two Wire System
- Range-ability 100:1
- LCD Display
- Application flexibility with HART Communication
- Non-Intrusive Magnetic Controls



Electronet series ELPRT-100SDP micro-controller based design which has capacitive type pressure sensing element. ELPRT100SDP is suitable for Differential Pressure measurements. It is used for various industrial applications. It can be used for Liquid, Gas & Vapor pressure measurements. It is having wide ranges of pressure with high accuracy & linearity output in the form of electrical signal 4–20 mA DC with HART communication.

Technical Specifications



Output Signal	
2-Wire-System	4–20mA with super imposed signal for HART protocol, digital communication
Supply Voltage	12.5 – 45 VDC
Signal Range	3.9mA – 20.8mA
Measuring Range	Refer Pressure Range Table
Electrical Protection	
Insulation Resistance	>100 MΩ at 100VDC
Wiring Protection	Protection against Over Voltage & Short Circuit
Reverse Polarity Protection	Available
Temperature Limits	
Ambient Conditions	–20 to 70°C
Storage	–40 to 85°C
Process Temperature	–20 to 125°C
Ingress Protection	IP 66
Performance	
Accuracy	1) $\pm 0.075\%$ of URL for SPAN $\geq 5:1$ 2) $\pm (0.05 + 0.03 \text{ of } (\text{URL} / \text{SPAN}))\%$ of SPAN for SPAN $< 5:1$
Static Pressure Effect	Zero Error: $\pm 0.25\%$ of URL per 50 Bar (Zero static pressure effect can be removed by zero trimming at line pressure.) Span Error: $\pm 0.35\%$ of URL per 50 Bar
Power Supply Effect	$< \pm 0.005\%$ of calibrated SPAN per volt
Vibration Effect	$< 0.2\%$ of SPAN/g @200Hz
Installation Position Effect	Zero shifts up to $\leq \pm 0.15\%$ of URL, which can be calibrated out. No SPAN effect.
Thermal Effect	Range code 4 to 8 Zero error = $\pm 0.3\%$ URL per 28°C Total error = $\pm 0.3\%$ URL + 0.25% of calibrated span per 28°C Double the effect for Range code 3, 2
Humidity	5–98%
Static Pressure	30 Bar to 130 Bar, Higher On Request
Stability	Less than $\pm 0.2\%$ of URL per Year
Transfer Function	Linear or square root
Over Pressure	2 times max. Pressure range
Burst Pressure	3 times max. Pressure range

Turndown Ratio	100:1
Turn On Time	Less than 5 Sec.
Response Time	200 ms (without considering electronic damping)
Damping	0.1 to 30.0 Sec.

Physical Specifications

Electrical connections	M20 x 1.5 / 1/2" NPT / 1/2" BSP / 3/4" ET
Process connection	1/4" NPT (M/F), 1/2" NPT (M/F), 1/4" BSP (M/F), 1/2" BSP (M/F), 5 Meter Capillary
Diaphragm	SS316 / SS316L / Hastelloy C / With Remote Seal
Flange	SS304 / SS316 / SS316L / Hastelloy C / SS304
Drain / Vent Valve	1/4" NPT – SS316 / SS304
Media wetted O-ring	Viton, Neoprene, EPDM, Red Silica
MOC Electronics Enclosure	Die Cast Aluminium PU Painted / SS316
Nuts, Bolts	M 10 X 96 mm – SS316 / SS304
Identification Plate	SS304 / Carbon steel with zinc coating
Mounting brackets	MS / Carbon steel with zinc coating or with painting / SS304 / SS316 / SS316L
Sight glass	Laminated safety glass
Filling Fluid	Silicon Oil / Inert
Electromagnetic Compatibility (EMC)	Compliance with IEC 61000-4-3 and IEC 61000-4-6 Radiated and Conducted Susceptibility

Others

Display Type	LCD Display
Display Visible Range	32.5 x 22.5mm
Main Display	5-Digit
Digit height	8 mm
Bar graph	51 Segments
Weight	Standard model approx. 3.4 Kg
Certification	
	 ATEX Certification : ATEX (II 2 GD Ex d IIC T6 Gb -20°C ≤ Ta ≤ +60°C)

Pressure Range Table

Range Code	Lower Range Limit (LRL)	Upper Range Limit (URL)	Minimum SPAN
2	-0.1885psi [-0.013 Bar]	0.1885psi [0.013 Bar]	0.00188psi [0.00013 Bar]
3	-1.160psi [-0.080 Bar]	1.160psi [0.080 Bar]	0.0116psi [0.0008 Bar]
4	-5.801psi [-0.400 Bar]	5.801psi [0.400 Bar]	0.0580psi [0.0040 Bar]
5	-29.007psi [-2.0 Bar]	29.007psi [2.0 Bar]	0.290psi [0.0200 Bar]
6	-100psi [-6.895 Bar]	100psi [6.895 Bar]	1psi [0.0689 Bar]
7	-300psi [-20.684 Bar]	300psi [20.684 Bar]	3psi [0.2068 Bar]
8	-1000psi [-68.948 Bar]	1000psi [68.948 Bar]	10psi [0.6894 Bar]

EMI/EMC Tests

No.	Tests	Basic Standards	Test Conditions	Performance Level
1	Conducted Emission (Mains)	CISPR11	150KHz-30MHz	A
2	Radiated Emission (in GTEM)	IEC61000-4-20	30MHz-1000MHz	A
3	Conducted Radio Frequency Immunity (Mains)	IEC61000-4-6	150KHz-80MHz	A
4	Electrical Fast Transient/Burst (EFT/B) Immunity (on Mains)	IEC61000-4-4	1KV(5/50nSec,5KHz)	B
5	Combination wave surge Immunity (on Mains)	IEC61000-4-5	1KV(Line to Line) (1.2/50us)	B
6	Immunity to Radiated Electromagnetic Fields (Amplitude Modulated)	IEC61000-4-3	80MHz – 1000MHz (10V/M)	A
7	Damped Oscillatory surge Immunity (on Mains)	IEC61000-4-18	1KV(Line to Ground) 0.5KV(Line to Line)	B
8	Electrostatic Discharge (ESD) Immunity	IEC61000-4-2	6KV(Contact) 8KV(Air)	A

Menu Function

Transmission Module Type

Output Signal	Local Control	Remote Control
4-20mA + HART	LCD/2 Buttons on Body	HART
4-20mA	LCD/2 Buttons on Body	-

Measuring Menu

Mark	State
URL	Upper Range Limit
LRL	Lower Range Limit

Analog Output Type

Parameters	Output Type
mA LINER	Linearity
mA√	Square Root

LCD Display Unit

Display mode	Details
PV	Process value shown on main screen
mA	Current shown on main screen
%	Percentage shown on main screen
Progress Bar	Progress bar shown on main screen top side

Units

Unit	Defination
bar	bar
mbar	Millibar
mmH2O	Millimeter of water @ 4° C
kg/cm ²	Kilogram per square centimeter
kPa	Kilopascal
mmHg	Millimeter of mercury @ 0° C
psi	Pounds per square inch
inH2O	Inch of Water

Power Supply & Load Requirements

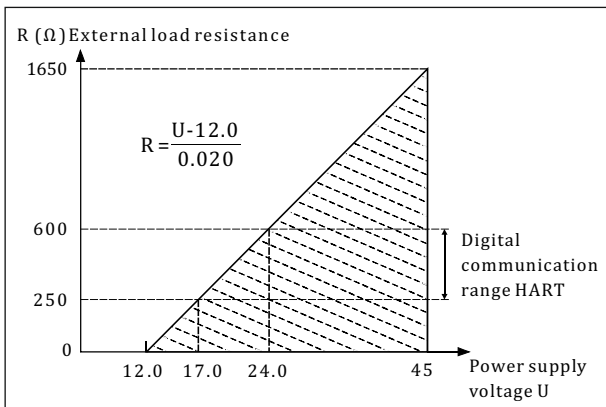

Product Drawing & Dimensions

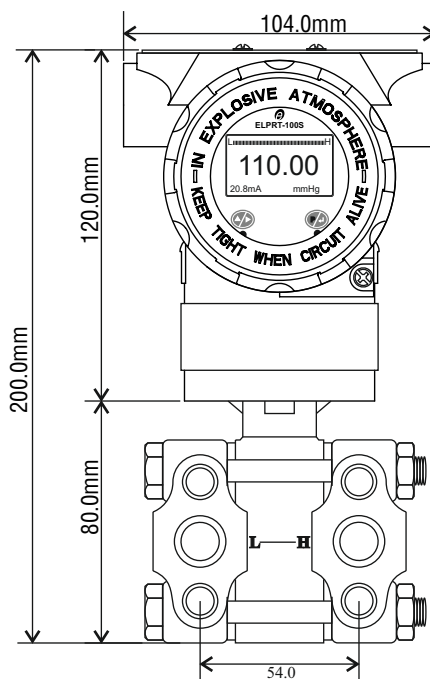

Fig.1 Front View

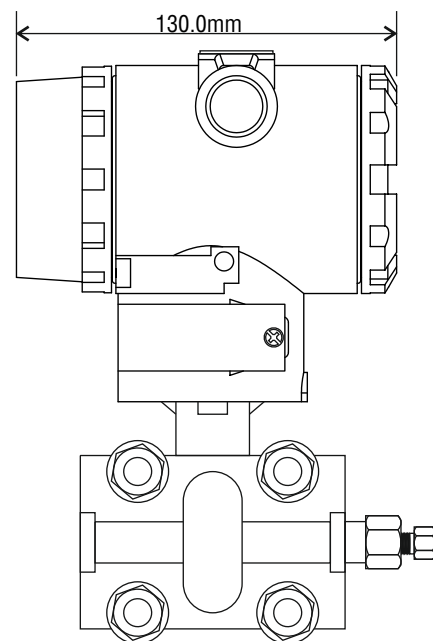
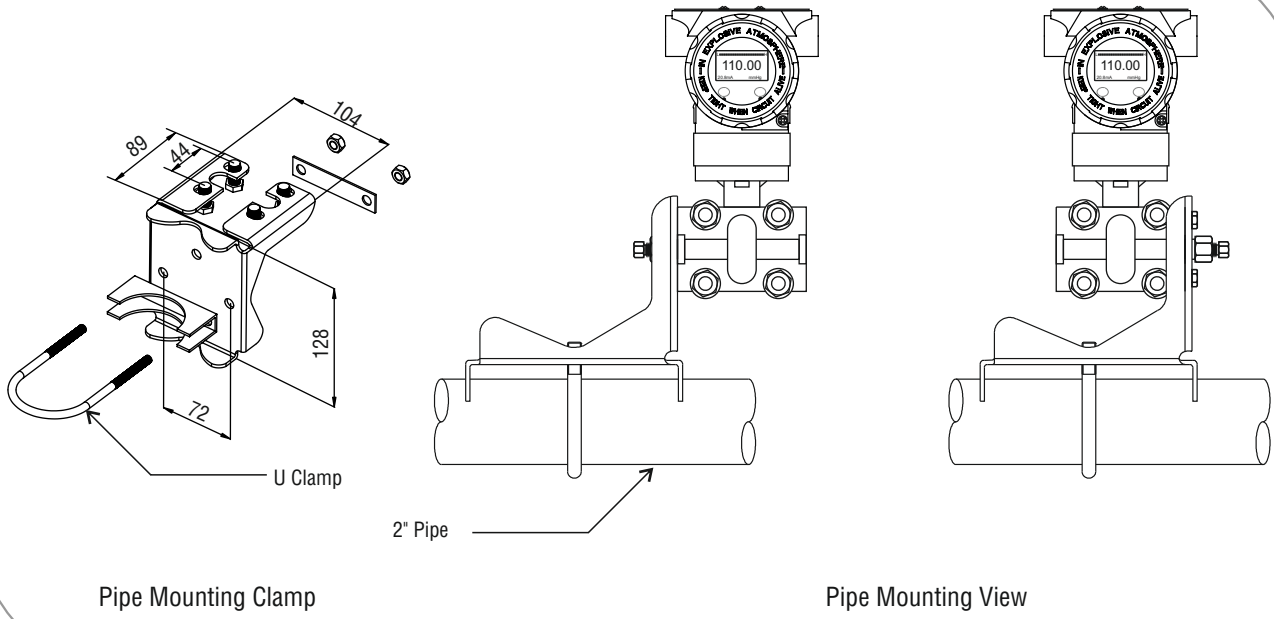

Fig.2 Side View

Installation Drawing & Dimensions

Pipe Mounting



Pipe Mounting Clamp

Pipe Mounting View

Wall Mounting

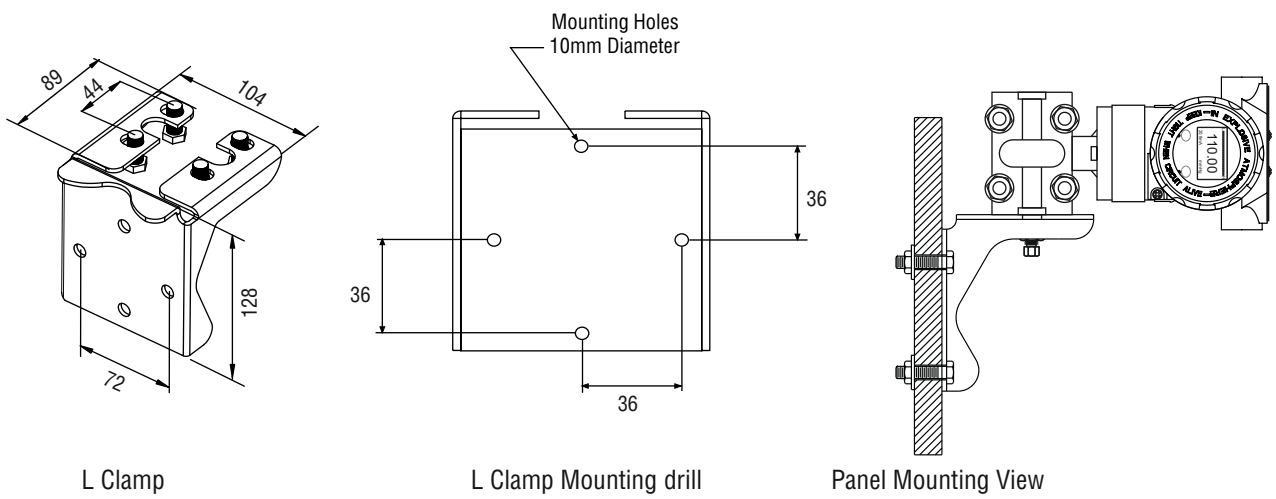

L Clamp

L Clamp Mounting drill

Panel Mounting View

Measuring Medium

Liquid, Gas or Steam

Field of Application

Pressure, Level,
Differential Pressure & Flow

Approvals



Ordering Information

Sample Order Code : B2 C2 F2 G2 H3 L1 M2 N2 O3 P6 Q1

Parameter	Code	Description	Parameter	Code	Description								
B	Pressure Range	B1	0.1885 psi	M	Fill Fluid	M1	Silicon Oil						
		B2	1.16 psi			M2	Inert						
		B3	5.801 psi			MY	Other						
		C	Area Classification	B4	29.007 psi	N	MOC of Sensor, Flange, Adapter & Drain Vent Valve	N1	SS316L				
				B5	100 psi			N2	Hastelloy C				
				B6	300 psi			NY	Other				
				B7	1000 psi	O	O Ring Material	O1	Buna – N				
C2	Field Mount Weather Proof IP66	O2	Ethylene – Propylene										
C3	ATEX	O3	Teflon										
C4	Flameproof CMRI IIA IIB	O4	Viton										
F	MOC Electronics Enclosure	F1	Aluminium Die Cast	P	Process Connection	P1	¼" NPT (M)						
G	Electrical Connection	F2	SS316			P2	½" NPT (M)						
		G1	M 20 x 1.5 (F)			P3	¼" BSP (M)						
		G2	½" NPT (F)			P4	½" BSP (M)						
H	Output (Any one)	GY	Other			P5	¼" NPT (F)						
		H1	4 to 20 mA			P6	½" NPT (F)						
		H3	4 to 20 mA with HART			P7	¼" BSP (F)						
L	Diaphragm Material	L1	SS316L			P8	½" BSP (F)						
		L2	Hastelloy C			P11	Diaphragm Seal 1"						
		LY	Other			P12	Diaphragm Seal 2"						
Note :	<ul style="list-style-type: none"> Due to our continuous product revisions, design specification and model numbers are subject to change without notice. Accuracy defined at Lab Conditions. For other requirement please consult factory. 												
										Q	Mounting Bracket	Q1	MS
												Q2	SS316

Applications

Food Industry	Chemical Industry	Atomic Energy	Manufacturing Industry
Automation Industry	Thermal Power Energy	Process Industry	Water Treatment Industry

ELECTRONET EQUIPMENTS PVT. LTD.

Factory Address:

Plot No. 8, (SEZ) Phase 1, Kesurdi MIDC, Khandala, Dist.- Satara Pin: 412 801, Maharashtra, India.

Registered Office:

Plot No. 84, 85, 86, Tiny Industrial Estate, Kondhwa Budruk, Pune-411 048, Maharashtra, India.

+91-20-26931476/2039 ho@eeplindia.com +91-20-26934122 www.eeplindia.com