

SMART

ELPRT-100SPT

PRESSURE TRANSMITTER



ELPRT-100SPT

ELPRT-100SPT With Remote Seal

FEATURES

- Piezo Resistive & Capacitive Sensor
- ATEX Certified
- Long Operational Life
- Excellent Long Term Stability
- Two Wire System
- Range-ability 100:1
- LCD Display with Backlight
- Faster Response Time
- Application flexibility with HART Communication



Electronet series ELPRT-100SPT (GP & AP) can accurately measure the pressure of gases, vapors and liquids used in refineries, petrochemicals, oil & gas, power, chemical industries, food processing & pharmaceutical industries. Based on a mechanical and rugged silicon sensor & capacitive sensor, the ELPRT-100SPT (GP & AP) is suitable for Absolute & Gauge Pressure Measurements.

Technical Specifications

Output Signal	
2-wire-system	4-20mA with super imposed signal for HART Protocol, Digital Communication
Supply Voltage	12.5 – 45 VDC
Signal Range	3.9mA – 20.8mA
Measuring Range	Refer Pressure Range Table
Electrical Protection	
Insulation Resistance	>100 MΩ at 100VDC
Wiring Protection	Protection against Over Voltage & Short Circuit
Reverse Polarity Protection	Available
Temperature Limits	
Ambient Conditions	-20 to 70°C
Storage	-40 to 85°C
Process Temperature	-20 to 125°C
Ingress Protection	IP 67
Electromagnetic Compatibility (EMC)	Compliant with IEC 61000-4-3 and IEC 61000-4-6 Radiated and Conducted Susceptibility



Performance

Accuracy	1) +/-0.075% of URL for SPAN ≥ 5: 1 2) +/- (0.025 + 0.015 of (URL / SPAN))% of SPAN for SPAN < 5: 1 *In case of remote seal process connection the accuracy will be less than +/- 1% of URL
Power Supply Effect	< ±0.005% of calibrated SPAN per volt
Vibration Effect	< 0.2% of SPAN/g @ 200Hz
Installation Position Effect	Zero shifts up to ≤ +/- 0.15% of URL, which can be calibrated out. No SPAN effect.
Thermal Effect	Range code 4 to 8
	Zero error = +/-0.3% URL per 28°C Total error = +/-0.3% URL +0.25% of calibrated span per 28°C
	Double the effect for Range code 3, 2
Turndown Ratio	100:1
Turn On Time	Less than 5 Sec.
Response Time	200 ms (without considering electronic damping)
Damping	0.1 to 30.0 Sec.
Humidity	5-98% Relative Humidity
Stability	Less than +/-0.2% of URL per Year
Over Pressure	2 times max. Pressure range
Burst Pressure	3 times max. Pressure range

Physical Specifications

Process Connection	1/4" NPT (M/F), 1/2" NPT (M/F), 1/4" BSP (M/F), 1/2" BSP (M/F)
Diaphragm	SS316 / SS316L / Hastelloy C / With Remote Seal
Seals	Viton / Neoprene / Red silica / EPDM
Wetted Parts	SS304 / SS316 / SS316L / Hastelloy C
MOC Electronic Enclosure	Die Cast Aluminium PU Painted / SS 316
Sight Glass	Laminated Safety Glass
Filling Fluid	Silicon Oil / Inert (for capacitive sensor)
Electrical Connection	M20*1.5 / 1/2"NPT (F)

Others

Display Type	LCD Display
Display Visible Range	32.5 x 22.5mm
Main Display	5-Digit
Digit Height	8 mm
Bar-graph	51 Segments
Weight	Standard model approx. 1.3 Kg
Certification	  ATEX Certification : ATEX (II 2 GD Ex d IIC T6 Gb -20°C ≤ Ta ≤ +60°C)

Pressure Range Table

Table A : Absolute Pressure Transmitter Ranges

Range Code	Lower Range Limit (LRL)	Upper Range Limit (URL)	Minimum SPAN
4	0	5.801psi (0.400 Bar)	0.0580 psi (0.0040 Bar)
5	0	29.007psi (2.0 Bar)	0.290 psi (0.0200 Bar)
6	0	100psi (6.895 Bar)	1 psi (0.0689 Bar)
7	0	300psi (20.684 Bar)	3 psi (0.2068 Bar)

Table B : Gauge Pressure Transmitter Ranges

Range Code	Lower Range Limit (LRL)	Upper Range Limit (URL)	Minimum SPAN
3	-1.160psi (-0.080 Bar)	1.160 psi (0.080 Bar)	0.0116 psi (0.0008 Bar)
4	-5.801psi (-0.400 Bar)	5.801 psi (0.400 Bar)	0.0580 psi (0.0040 Bar)
5	-14.7 psi (-1.013 Bar)	29.007 psi (2.0 Bar)	0.290 psi (0.0200 Bar)
6	-14.7 psi (-1.013 Bar)	100 psi (6.895 Bar)	1 psi (0.0689 Bar)
7	-14.7 psi (-1.013 Bar)	300 psi (20.684 Bar)	3 psi (0.2068 Bar)
8	-14.7 psi (-1.013 Bar)	1000 psi (68.948 Bar)	10 psi (0.6894 Bar)
9	-14.7 psi (-1.013 Bar)	3000 psi (206.843 Bar)	30 psi (2.0684 Bar)
10	-14.7 psi (-1.013 Bar)	6000 psi (413.685 Bar)	60 psi (4.1368 Bar)
11	-14.7 psi (-1.013 Bar)	10000 psi (689.47 Bar)	100 psi (6.8947 Bar)

EMI/EMC Tests

No.	Tests	Basic Standards	Test Conditions	Performance Level
1	Conducted Emission (Mains)	CISPR11	150KHz-30MHz	A
2	Radiated Emission (in GTEM)	IEC61000-4-20	30MHz-1000MHz	A
3	Conducted Radio Frequency Immunity (Mains)	IEC61000-4-6	150KHz-80MHz	A
4	Electrical Fast Transient / Burst (EFT/B) Immunity (on Mains)	IEC61000-4-4	1KV(5/50nSec,5KHz)	A
5	Combination Wave Surge Immunity (On Mains)	IEC61000-4-5	1KV(Line to Line) (1.2/50us)	A
6	Immunity to Radiated Electromagnetic Field (Amplitude Modulated)	IEC61000-4-3	80MHz - 1000MHz (10V/M)	A
7	Damped Oscillatory Surge Immunity (On Mains)	IEC61000-4-18	1KV(Line to Ground) 0.5KV(Line to Line)	A
8	Electrostatic Discharge (ESD) Immunity	IEC61000-4-2	6KV(Contact) 8KV(Air)	A

Menu Function

Transmission Module Type

Output Signal	Local Control	Remote Control
4-20mA + HART	LCD/2 Buttons on Body	HART
4-20mA	LCD/2 Buttons on Body	-

Measuring Menu

Mark	State
URL	Upper Range Limit
LRL	Lower Range Limit

Analog Output Type

Parameters	Output Type
mA LINER	Linearity

LCD Display Unit

Display mode	Details
PV	Process value shown on main screen
mA	Current shown on main screen
%	Percentage shown on main screen
Progress Bar	Progress bar shown on main screen top side

Units

Unit	Defination
bar	bar
mbar	Millibar
mmH2O	Millimeter of water @ 4° C
kg/cm ²	Kilogram per square centimeter
kPa	Kilopascal
mmHg	Millimeter of mercury @ 0° C
psi	Pounds per square inch
inH2O	Inch of Water

Power Supply & Load Requirements

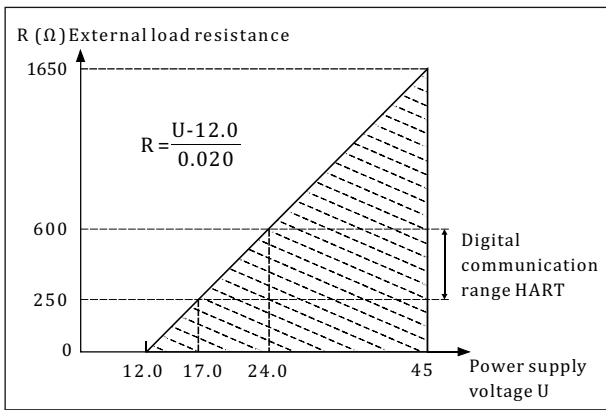

Product Drawing & Dimensions

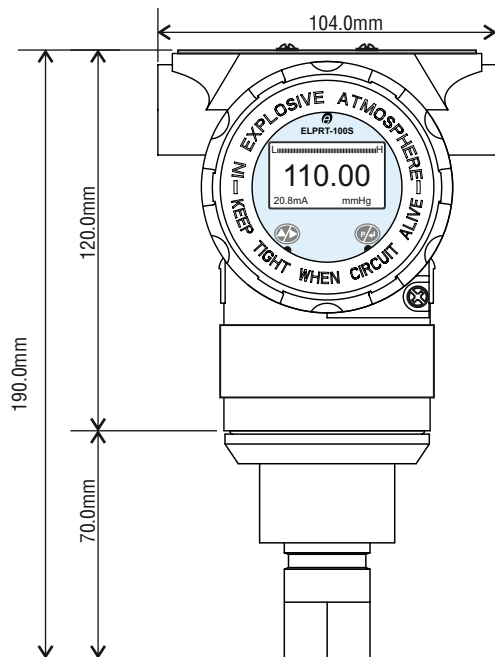

Fig.1 Front View

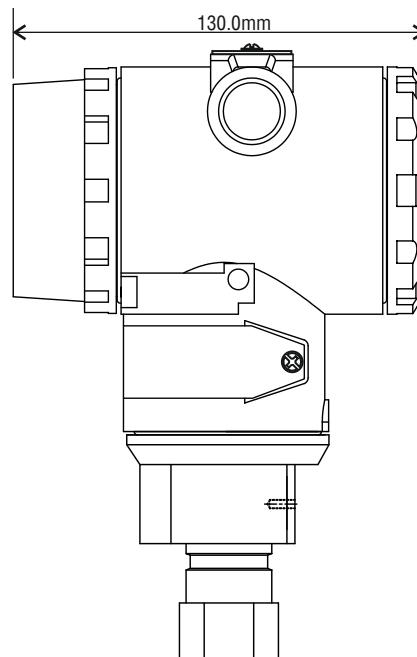
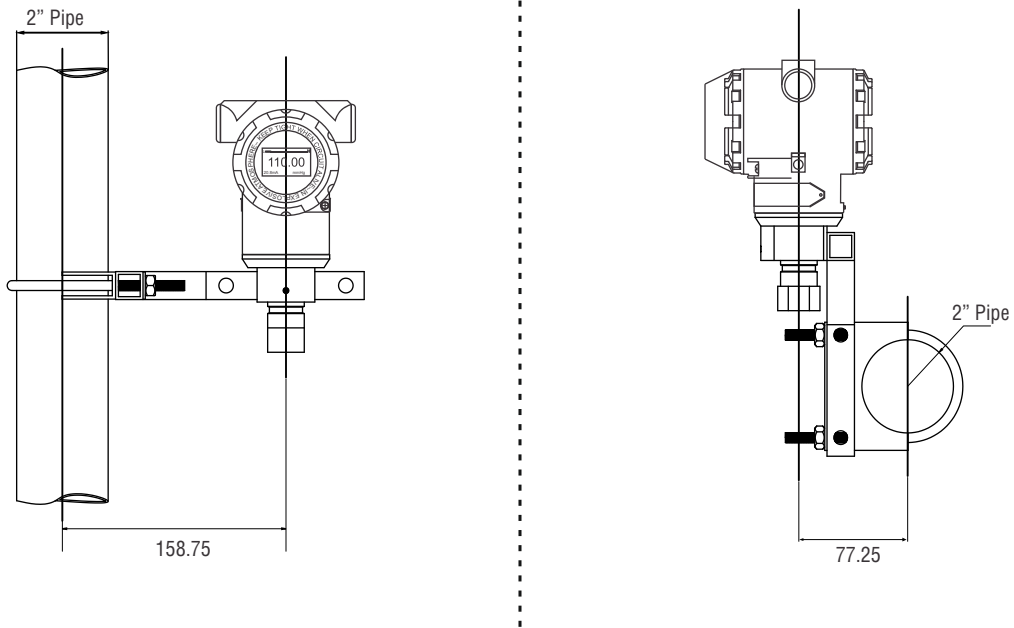

Fig.2 Side View

Installation Drawing & Dimensions

Pipe Mounting



Installation Drawing & Dimensions

Panel Mounting

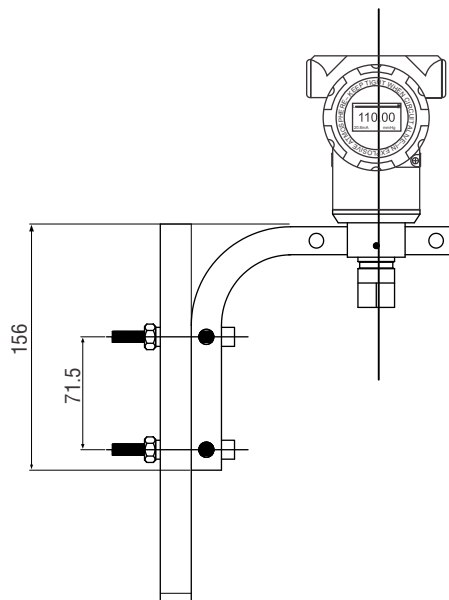

Measuring Medium

Liquid, Gas or Steam

Field of Application

Pressure & Level

Approvals



Ordering Information

Sample Order Code : A1 B2 C2 F2 G2 H3 L1 M2 N2 O3 P6 Q1

Parameter	Code	Description	Parameter	Code	Description				
A	Measurement Type	A1	AP	M	Fill Fluid	M1	Silicon Oil		
		A2	GP			M2	Inert		
B	Pressure Range	B1	0.1885 psi			N	MOC of Sensor, Flange, Adapter	MY	Other
		B2	1.16 psi	N1	SS316L				
		B3	5.801 psi	N2	Hastelloy C				
		B4	29.007 psi	NY	Other				
		B5	100 psi	O	O Ring Material	O1	Buna – N		
		B6	300 psi			O2	Ethylene – Propylene		
		B7	1000 psi			O3	Teflon		
		B8	3000 psi			O4	Viton		
		B9	6000 psi			P	Process Connection	P1	¼" NPT (M)
		B10	10000 psi					P2	½" NPT (M)
AP URL : From 0.1885 to 300 psi & GP URL : From 0.1885 to 10000 psi			P3					¼" BSP (M)	
C	Area Classification	C2	Field Mount Weather Proof IP67	P4	½" BSP (M)				
		C3	ATEX	P5	¼" NPT (F)				
		C4	Flameproof CMRI IIA IIB	P6	½" NPT (F)				
F	MOC Electronics Enclosure	F1	Aluminium Die Cast	P7	¼" BSP (F)				
		F2	SS316	P8	½" BSP (F)				
G	Electrical Connection	G1	M 20 x 1.5 (F)	P9	Flush Diaphragm (Triclover)				
		G2	½" NPT (F)	P10	Flush Diaphragm (1" BSP)				
		GY	Other	P11	Diaphragm Seal 1"				
H	Output (Any one)	H1	4 to 20 mA	P12	Diaphragm Seal 2"				
		H3	4 to 20 mA with HART	P13	Diaphragm Seal 3"				
L	Diaphragm Material	L1	SS316L	P14	5 Mtr Capillary (1" Flange)				
		L2	Hastelloy C	P15	5 Mtr Capillary (2" Flange)				
		LY	Other	P16	5 Mtr Capillary (3" Flange)				
Note : <ul style="list-style-type: none"> Due to our continuous product revisions, design specification and model numbers are subject to change without notice. Accuracy defined at Lab Conditions. For other requirement please consult factory. 			Q	Mounting Bracket	PY	Other			
					Q1	MS			
					Q2	SS316			

Applications

Food Industry	Chemical Industry	Atomic Energy	Manufacturing Industry
Automation Industry	Thermal Power Energy	Process Industry	Water Treatment Industry

ELECTRONET EQUIPMENTS PVT. LTD.

Factory Address:

Plot No. 8, (SEZ) Phase 1, Kesurdi MIDC, Khandala, Dist.- Satara Pin: 412 801, Maharashtra, India.

Registered Office:

Plot No. 84, 85, 86, Tiny Industrial Estate, Kondhwa Budruk, Pune-411 048, Maharashtra, India.

+91-20-26931476/2039 ho@eeplindia.com +91-20-26934122 www.eeplindia.com